

Manual

# PROFIBUS Tester 4 BC-600-PB

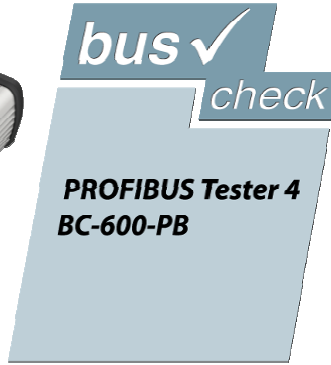

Version 1.04  
Revision 2010-05-02



© Copyright 2010 Softing AG

No part of this manual may be reproduced, photocopied, stored on a retrieval system, transmitted, processed or translated without the express prior written consent of Softing AG.

# Contents

<b>1</b>	<b>Introduction</b>	<b>6</b>
1.1	General	6
1.2	Test Functions	6
1.3	Operating Modes of the Tool	6
1.4	PROFIBUS Diagnostics Suite PC Software	7
<b>2</b>	<b>Delivery Scope</b>	<b>8</b>
<b>3</b>	<b>Optional Accessories</b>	<b>9</b>
3.1	Adapter Set for M12 Connection Technology	9
3.2	Fieldbus Shield Digital Leakage Current Clamp	9
3.3	Portable Power Supply	10
3.4	Service Interface for PROFIBUS DP	11
3.4.1	Connection Type D-sub	11
3.4.2	Connection Type M12	12
<b>4</b>	<b>Connectors and Controls</b>	<b>13</b>
<b>5</b>	<b>Power Supply and Auto Power On</b>	<b>14</b>
5.1	Power-Up Behavior without USB Connection	14
5.2	Power-Up Behavior when USB Connected	15
<b>6</b>	<b>Software Installation</b>	<b>16</b>
6.1	Connection to a PC	16
<b>7</b>	<b>Connection to PROFIBUS</b>	<b>16</b>
7.1	Basics	16
7.1.1	Warning notice for testing a live bus	16
7.1.2	Connection types	17
7.1.3	Adapter cable	17
7.1.4	Strain relief	18
7.1.5	Test locations	18
7.2	Simple Connection for Tests During System Shutdown	19
7.3	Connection for Testing a Live Bus	20
7.3.1	Connection via D-sub connector with service socket	21
7.3.2	Direct cable connection	22
7.3.3	Connection via M12 connector	23
7.4	Master Simulator and Topology Scan	23
7.4.1	Special case: Active devices at both ends of the bus	25

<b>8</b>	<b>Display and Control in Stand-Alone Mode</b>	<b>26</b>
8.1	Main Display	26
8.2	Operating Concept	28
8.3	Functions	29
8.3.1	Live Status function	29
8.3.1.1	Segment status	29
8.3.1.2	Station status	30
8.3.2	Quick Test function	31
8.3.3	Trend function	31
8.3.4	Master Simulator function	31
8.3.5	Settings and Help functions	32
<b>9</b>	<b>Firmware Update</b>	<b>32</b>
<b>10</b>	<b>Maintenance and Servicing</b>	<b>32</b>
<b>11</b>	<b>Troubleshooting</b>	<b>33</b>
<b>12</b>	<b>Specifications</b>	<b>34</b>
<b>13</b>	<b>General Notes</b>	<b>35</b>
13.1	Lithium Battery	35
13.2	CE Conformity	35

# 1 Introduction

## 1.1 General

The PROFIBUS Tester 4 is a powerful tool that allows full testing of live PROFIBUS DP segments broadly without interfering with their operation. The tool reliably detects even transient faults that occur only sporadically.

Using the integrated master simulator, you can also test the bus if the PLC is currently not in operation, or individually check “suspicious” bus stations.

The tool is powered either through an external AC adapter, by direct connection to 24 VDC or through an optional portable power supply unit.

## 1.2 Test Functions

The PROFIBUS Tester 4 automatically detects the baud rate or open circuit voltage as soon as you connect it to a PROFIBUS DP segment. The following standard tests are available for **simultaneously analyzing the bus physics and bus communication**:

- Quick test
- User-controlled test
- Long-term trend

Additional features (network status):

- Master simulator
- Topology scan

Expert tests (optional):

- Frame analysis
- Oscillogram analysis
- Trigger input/output

## 1.3 Operating Modes of the Tool

You can connect the PROFIBUS Tester 4 to a PC or notebook, or run it in stand-alone mode. The PC mode provides all standard and expert tests. You can also select individual stations you want to test. The stand-alone mode currently provides the live status and the master simulator mode. In addition, it is planned to soon make available the quick test and long-term trend functions as well as the transfer of test results to the PC.

## 1.4 PROFIBUS Diagnostics Suite PC Software

The PROFIBUS Diagnostics Suite allows the display and detailed analysis of test results on the PC.

Simply connect the PROFIBUS Tester 4 to the USB interface of a PC or notebook. You can then use the included “PROFIBUS Diagnostics Suite” PC software (see separate manual) to do the following:

- Perform tests and analyses
- Manage the test results with minimum effort
- Create test reports

Which operating modes of the PC software are available for testing depends on the license you obtain:

License	Operating mode			
	Network status	Long-term trend	Oscillograms	Frames
BC-600-PB	✓	✓	✓	✓

## 2 Delivery Scope

The PROFIBUS Tester 4 comes in a carrying case comprising:

- Test tool with RS485 interface
- Wide-range power supply with European and US mains power cables
- Connecting cable for direct power supply with 24 VDC
- RS485 D-sub adapter cable No. 1 “Plant in operation” (purple) for PROFIBUS DP
- RS485 D-sub adapter cable No. 2 “Master sim./Topology” (black) for PROFIBUS DP
- USB cable, 3 m
- Terminal block for trigger input/output
- CD-ROM with driver software, PC software and detailed integrated help system in English and German
- PROFIBUS Tester 4 user manual and Getting Started manual for the PROFIBUS Diagnostics Suite PC software



Fig. 1: BC-600-PB with carrying case

### 3 Optional Accessories

#### 3.1 Adapter Set for M12 Connection Technology

Using the M12 adapter set, you can connect the PROFIBUS Tester 4 to field devices with M12 connectors. The set comprises an M12 adapter cable with special pin layout and an M12 terminating resistor that you can screw on, if required.



Fig. 2: Special adapter set for M12

Softing Order No.: BC-600-PB-CB-M12

#### 3.2 Fieldbus Shield Digital Leakage Current Clamp

When routing PROFIBUS cables in high-interference environments, electromagnetic interference can affect the signal quality. By measuring the shield currents with the digital leakage current clamp, you can locate EMC problem areas and take appropriate countermeasures. The digital leakage current clamp is supplied in a handy case, including measuring cables.

There is also an empty compartment for the fieldbus shield digital leakage current clamp in the carrying case of the BC-600-PB.



Fig. 3: Fieldbus shield digital leakage current clamp

Softing Order No.: PB-LSZ-CHB3

### 3.3 Portable Power Supply

The portable power supply unit allows up to 4 hours of portable operation. The power supply kit also includes a charger and a carrying case.

Attention: Mains connector type of charger station available for Europe only.



Fig. 4: Portable power supply

Softing Order No.: BC-MOST-PB

## 3.4 Service Interface for PROFIBUS DP

### 3.4.1 Connection Type D-sub

The D-sub service interface provides a PROFIBUS access point for testing if the existing D-sub connectors have no service socket or if the bus stations are connected via a terminal block. The service interface can power the terminating resistor of the D-sub connector. You can thus use it as an active bus termination at the beginning or end of the bus.

If the PLC allows dropping and adding bus stations on the live bus, you will need this external bus termination to be able to exchange the first and last bus stations without causing problems on the bus.

The compact unit is rail mounted like a terminal block and powered by an external 24 VDC power supply. The package includes an 90° angled PROFIBUS connector with a switchable terminating resistor.

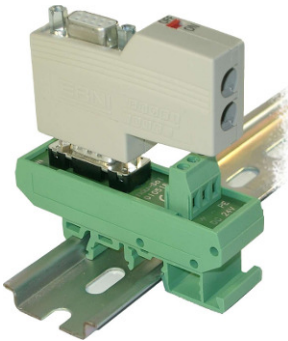

Fig. 5: D-sub service interface for testing a live bus

Softing Order No.: BC-PBMB-PB-S

### 3.4.2 Connection Type M12

The M12 service interface comprises an IP68 rated T piece, an end cap for the service output of the T piece, and a 1m PROFIBUS DP cable fitted with a male/female M12 connector on each end.



Fig. 6: M12 service interface for testing a live bus

Softing Order No.: BC-M12DP-PB

### 4 Connectors and Controls

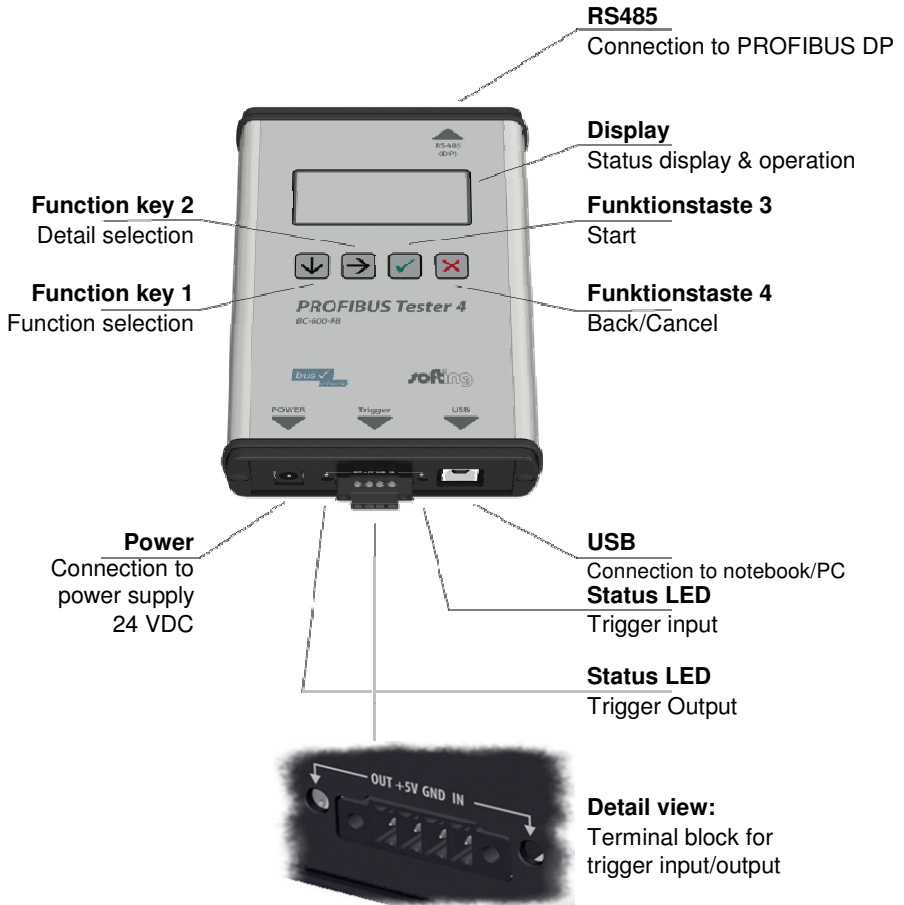

Fig. 7: Connectors and status displays on the BC-600-PB

## 5 Power Supply and Auto Power On

The tool is powered with 24 VDC either through the external AC adapter or by using the single-ended cable for direct 24 VDC power supply. Both are included in delivery.



Attention: Before being connected to the AC mains power, the PROFIBUS Tester 4 and the AC adapter must be acclimated to room temperature to avoid condensation. This may take up to 60 minutes.

The tool switches on automatically when you connect it to a power supply. The display lights up and self-test starts.



Attention: When the tool is connected directly to 24 VDC, there is no galvanic isolation to the external power supply. Insufficient potential equalization between the power supply and the PROFIBUS will lead to equalizing currents which can falsify the test results and, in the worst case, even destroy the PROFIBUS Tester 4 and part of the bus installation. In these cases, use of the supplied AC adapter is mandatory for operating the PROFIBUS Tester 4.

### 5.1 Power-Up Behavior without USB Connection

The PROFIBUS Tester 4 starts up in stand-alone mode in this case (see page [26](#)) and is immediately ready for testing.

## 5.2 Power-Up Behavior when USB Connected



Attention: The “PROFIBUS Diagnostics Suite” PC software also includes the required USB driver. You therefore need to install the software first before connecting the test tool to the PC or notebook.

On successful completion of the self-test, the PROFIBUS Tester 4 displays:

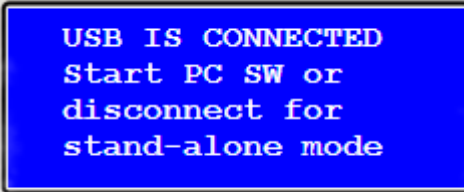

Fig. 8: Power-up display when USB connected

When you start the PROFIBUS Diagnostics Suite control and evaluation software on your computer and select the PROFIBUS Tester and a network for testing in its user interface, the test tool switches to PC mode. The display shows:

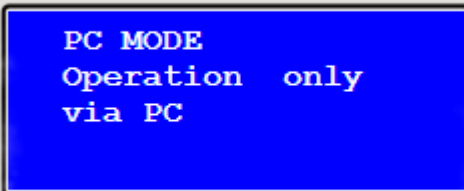

Fig. 9: Display at testing with PC software

While in PC mode, you can only display readings and operate the tool by using the control and evaluation software on the computer.

At this point, you can also start a firmware update instead of using the control and evaluation software. See page [32](#).

## 6 Software Installation

The “PROFIBUS Diagnostics Suite” PC software is provided on the included CD-ROM. You need administrator privileges to install the software. If the CD-ROM does not start automatically when inserted, please run the “start.exe” file in the main directory.

Future updates can be downloaded from our web site at [www.softing.com](http://www.softing.com), under INDUSTRIAL AUTOMATION in the section DOWNLOADS.



**Attention:** The “PROFIBUS Diagnostic Suite” PC software also includes the required USB driver. You therefore need to install the software first before connecting the test tool to the PC or notebook.

The installation and basic use of the PC software is described in the separate PROFIBUS Diagnostics Suite – Getting Started manual.

### 6.1 Connection to a PC

Use the included USB cable to connect the tool to a PC or notebook. Power is also supplied from the USB interface.



**Attention:** It is recommended to connect the unit directly to a USB port on the PC or notebook. When you use external USB hubs or notebook docking stations for connection, problems can occur.

## 7 Connection to PROFIBUS

### 7.1 Basics

#### 7.1.1 Warning notice for testing a live bus



**Attention:** When you connect a test tool, side effects on the system under test are generally unavoidable. The purple D-sub adapter cable 1 that is supplied with the PROFIBUS Tester 4 has been optimized to allow tests on live installations with minimum side effects. If the PROFIBUS is already disturbed to a certain degree or if Simatic Diagnostic Repeaters are used, the operation of the PROFIBUS might nevertheless be affected occasionally. Compliance with the connection notes is mandatory! The black D-sub adapter cable 2 and the black M12 adapter cable must not be used on a live installation!

### 7.1.2 Connection types

There are several ways to connect a bus station to a PROFIBUS network:

- Using connectors
  - D-sub connectors, most of which have an integrated terminating resistor and, optionally, an additional service socket
  - M12 connectors for environments requiring increased IP ratings
  - Special vendor-specific hybrid connectors; they are used in combination with special cables to supply power via the bus
- Using terminals for direct connection

Due to the typical daisy-chain topology, the connection points of the bus stations are the only possible points for connecting the test tool in most cases.

### 7.1.3 Adapter cable

The PROFIBUS Tester 4 is supplied with two D-sub adapter cables. The short purple cable no. 1 allows connection to a live PROFIBUS with minimum influence on bus operation. The longer black cable no. 2 is required for using the master simulator and the topology scan feature (see page [23](#)). An M12 adapter set is optionally available, see “Optional Accessories” on page [9](#).



Attention: Use only the short original cables with special pin layout to connect the unit to a PROFIBUS network. Do not cascade more than two D-sub connectors with service sockets at the same time:

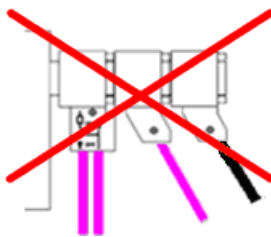

Fig. 10: Unallowed cascading of D-sub connectors

Active connection cables with integrated repeaters, such as Softing's BC-131-PB, cannot be used for testing.

**7.1.4 Strain relief**



Attention: When you connect the PROFIBUS Tester 4, its weight can place a high mechanical stress on the connectors and the bus station. Ensure proper strain relief by using suitable supports, cable ties, etc. When this is not possible, you need to select a different connection point to avoid damage.



Fig. 11: Strain relief fittings

**7.1.5 Test locations**

The PROFIBUS Tester 4 can basically carry out tests anywhere on a physical PROFIBUS segment. Please note that the use of repeaters creates separate physical segments that each need to be measured individually.

For the best and most informative results, perform the tests at the beginning and end of each physical segment. If these test results indicate problems that cannot be clearly classified right away, you should carry out one or more additional tests at the center.

## 7.2 Simple Connection for Tests During System Shutdown

If all bus stations provide D-sub connectors with an additional service socket, you can simply plug in the PROFIBUS Tester 4 at that socket (see figure below). If a D-sub connector does not provide a service socket, you can plug in the D-sub adapter cable No. 1 underneath. The only thing you need to keep in mind is that you should never cascade more than two D-sub connectors (see page 17).

When using M12 connection technology, the M12 adapter cable is “looped” into the bus. It is essential to ensure proper termination at the beginning and end of the bus by using the terminating resistor provided with the M12 adapter set.



Attention: All these simple connection types will divide the bus. You therefore need to shut down the PLC and all the devices connected to the PROFIBUS; in other words, you need to shut down the whole installation.

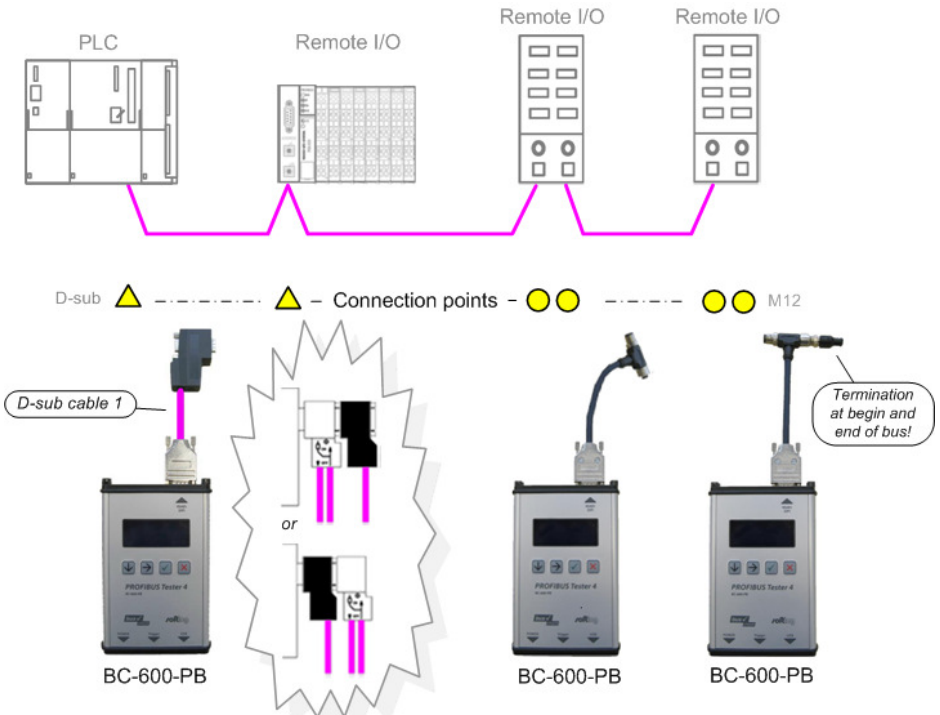

Fig. 12: Connection points at system shutdown

### 7.3 Connection for Testing a Live Bus

To test a live PROFIBUS with the PROFIBUS Tester 4 during operation, appropriate connection possibilities have to be provided. If no suitable connection points are available in the existing installation, it is recommended to install them during system shutdown. This will make future maintenance work much easier.



Attention: When installing additional connection points, you divide the bus. Before doing so, you therefore need to shut down the PLC and all the devices connected to the PROFIBUS; in other words, you need to shut down the whole installation.



Attention: Use only D-sub cable 1 when testing a live PROFIBUS installation.

### 7.3.1 Connection via D-sub connector with service socket

If all bus stations provide D-sub connectors with an additional service socket, you can simply plug in the PROFIBUS Tester 4 at that socket (see figure below).

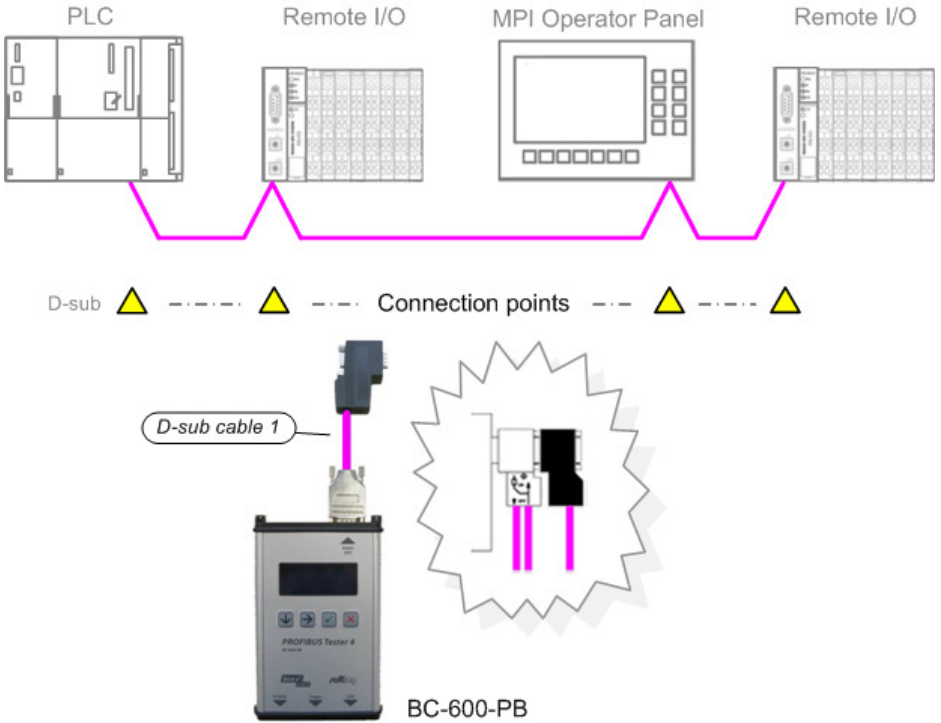

Fig. 13: Connection points for the D-sub adapter cable

### 7.3.2 Direct cable connection

To test a live PROFIBUS, you will need additional D-sub service interfaces of the type BC-PBMB-PB-S (see page [11](#)).

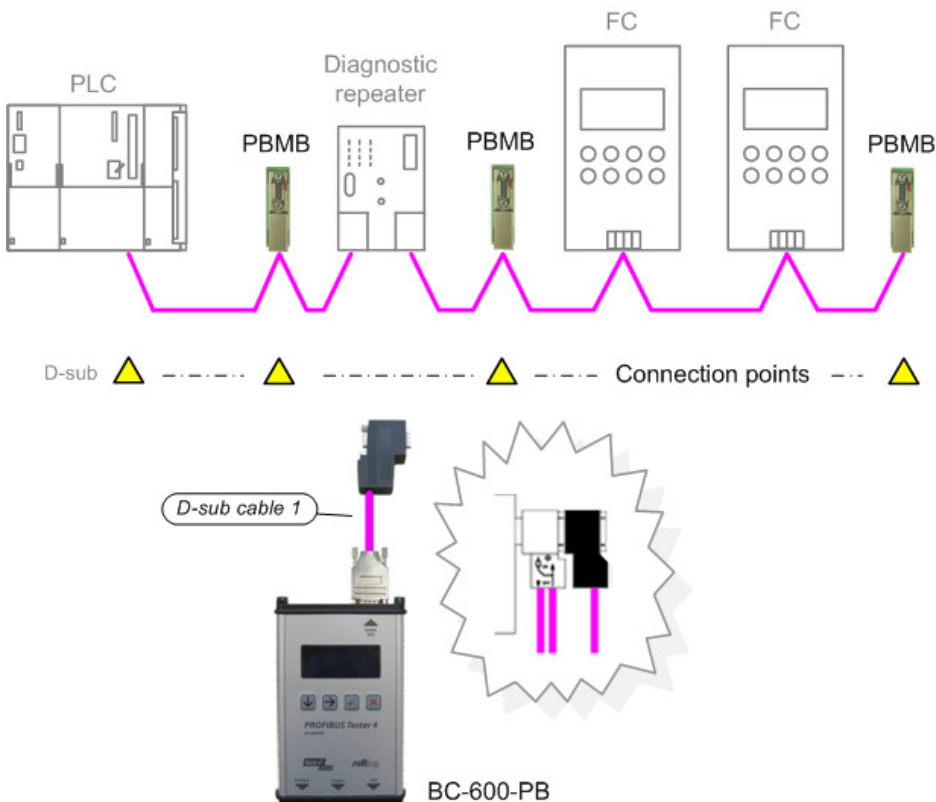

Fig. 14: Service interfaces provide connection points at direct cable connection

### 7.3.3 Connection via M12 connector

Tests on a live PROFIBUS are only allowed on bus segments providing D-sub connection technology. Only D-sub connectors with service socket can be used as connection points for the test tool. For this reason, tests can often only be performed at a bus end.

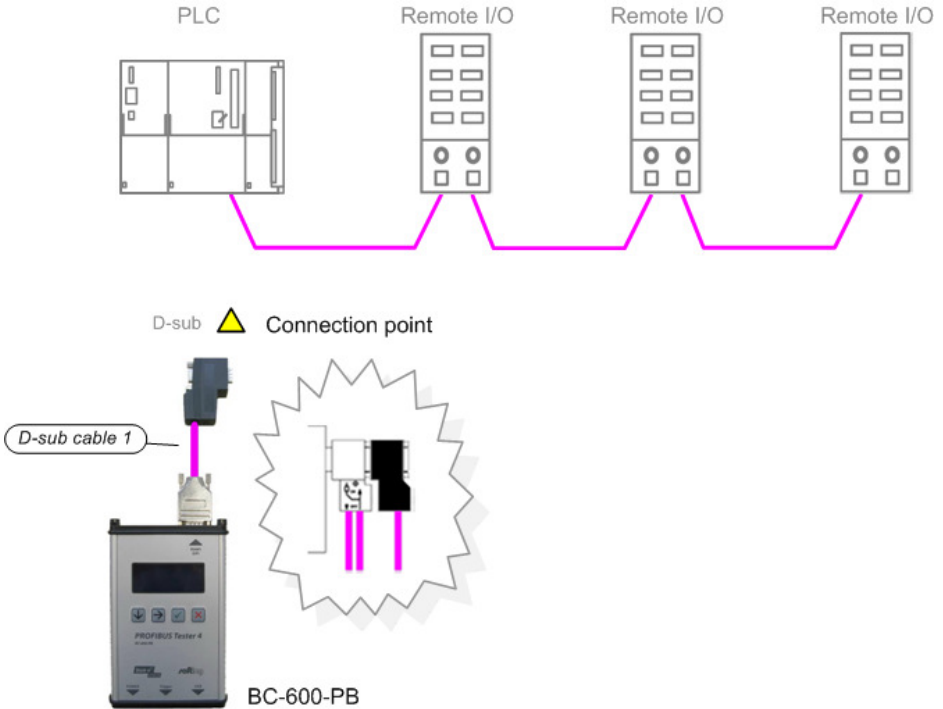

Fig. 15: Connection points for the M12 adapter cable

### 7.4 Master Simulator and Topology Scan

The master simulator allows checking the bus cabling and the station addresses during installation and commissioning, when the PLC (master) is not in operation yet. In addition, you can use this mode to check individual “suspicious” bus stations that have been disconnected from the bus.

The topology scan determines the sequence and distances of all passive bus stations (slaves). This feature requires correct bus cabling, a very good signal quality, and a connection point located directly at the beginning or end of the bus.

Both features can only be used during shutdown of the installation. The D-sub cable 2 must be used. As long as communication is detected on the bus, i.e. at least one device is an active master, the functions are disabled. If necessary, disconnect every single active device (PLC, MPI and, if necessary, diagnostic repeaters) from the power supply or the bus. If an active device is at the end of the bus you want to test, its PROFIBUS connector needs to be unplugged and connected directly to the PROFIBUS Tester 4. The bus termination in the device connector will then be powered by the PROFIBUS Tester 4.

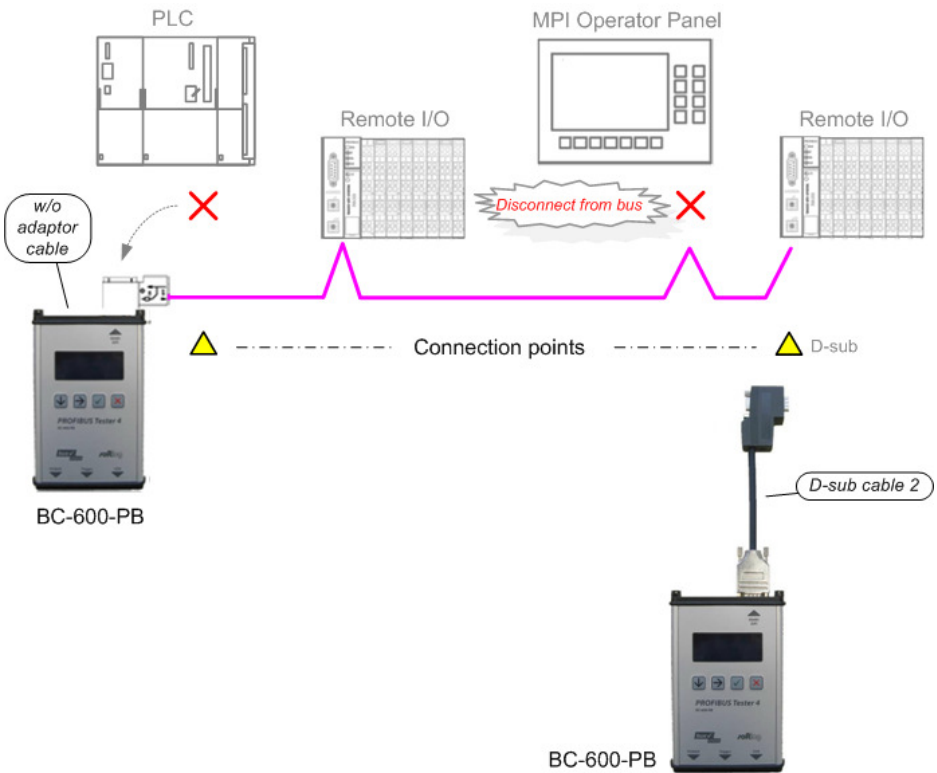

Fig. 16: Connection points for topology scan



Attention: Bus stations must only be disconnected from the power supply or the bus during shutdown of the installation.



Attention: The two functions can be started also when the PROFIBUS Tester 4 is disconnected from the bus. If you then connect the PROFIBUS Tester 4 to a live bus despite the yellow bus status bar indicated by the PC software, this can cause bus communication problems or a shutdown of the installation.

#### 7.4.1 Special case: Active devices at both ends of the bus

On the very rare occasion when there is an active device at each end of the bus, do the following:

1. When using D-sub connection:
  - Additionally switch on the terminating resistor in the D-sub connector of the last slave. The outgoing cable to the active device at the bus end has to be connected to the outgoing connector (marked with “OUT”, an outgoing arrow, or “A2/B2”).

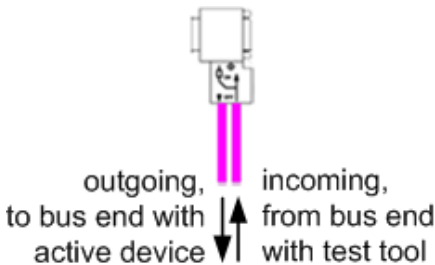

Fig. 17: Checking the connection direction at the D-sub connector

2. When using M12 connection:
  - The cable from the bus start or test tool has to be connected to the incoming M12 connector of the last slave. A bus termination is required at the outgoing M12 connector of the last slave.

## 8 Display and Control in Stand-Alone Mode

The PROFIBUS Tester 4 always starts in stand-alone mode unless it is USB connected to a PC or notebook. The readings are shown on the display. You can control the tool with the four function keys.

When you establish a USB connection during stand-alone mode while a test is running, the test will be aborted and the tool will be reset (restart). The display briefly shows: "Changing operating mode – Please wait ...".

### 8.1 Main Display

The baud rate of a connected PROFIBUS network is detected and displayed automatically:

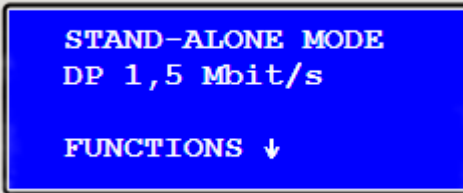

Fig. 18: Main display - example of a live PROFIBUS at 1.5 Mbit/s

The PROFIBUS status is shown in line 2. The following displays are possible:

3. The PROFIBUS is not connected:
  - Display: “DP n/a”
4. The PROFIBUS is connected, but no master is active:
  - Display of the static RS485 bus voltage, e.g. “DP 1015 mV stat.”
5. The PROFIBUS is connected and one or more masters are active:
  - Display of the detected baud rate, e.g. “DP 1.5 Mbit/s”

The status of the integrated master simulator is shown in line 3. The following displays are possible:

1. The master simulator is disabled:
  - The display remains blank.
2. The master simulator has been enabled manually (see page [31](#)):
  - Display: “M.Sim. ON”

The only control on the main display is the down arrow key with which you can select the individual functions.

## 8.2 Operating Concept

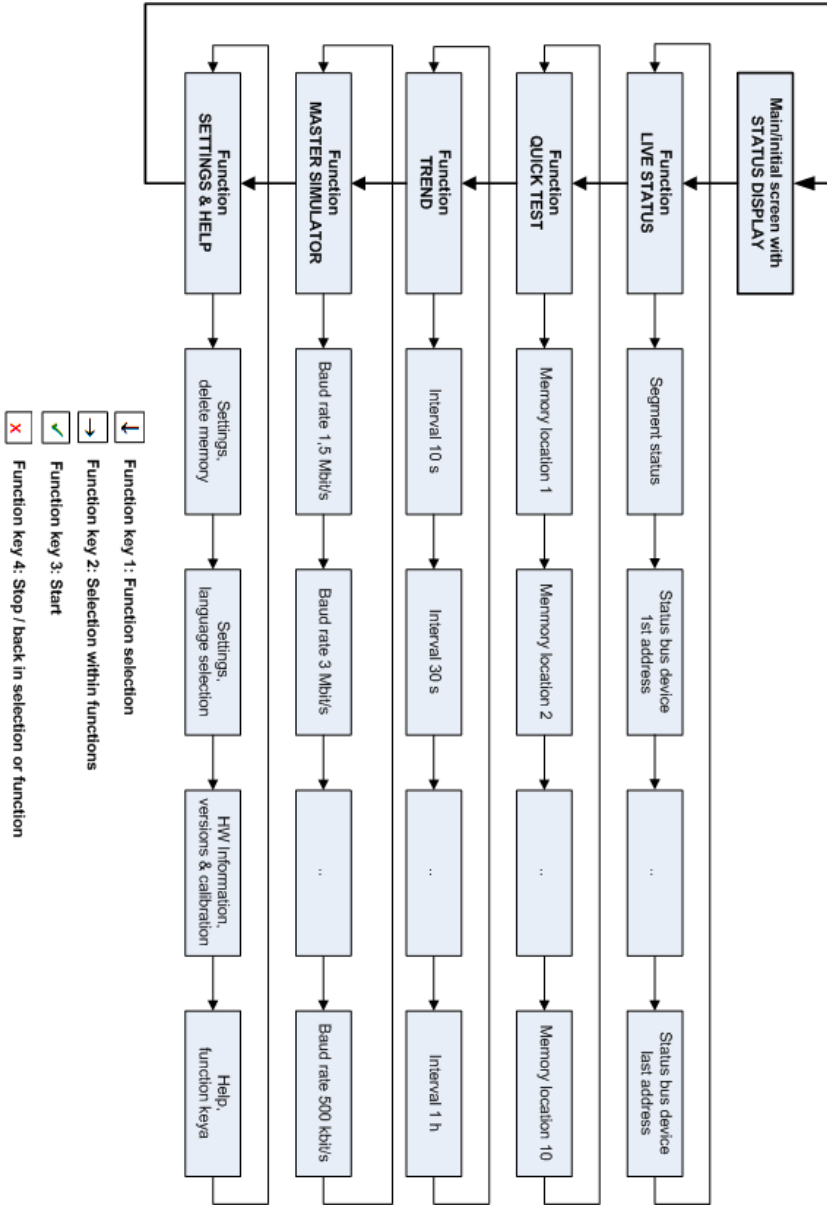

Fig. 19: Display control with the four function keys

## 8.3 Functions

### 8.3.1 Live Status function

The Live Status function very quickly gives you an overview of the bus status. Even transient disturbances during the test are reliably detected. Once you start the function, the tool determines and continuously updates the status for the segment and for each bus station.

#### 8.3.1.1 Segment status

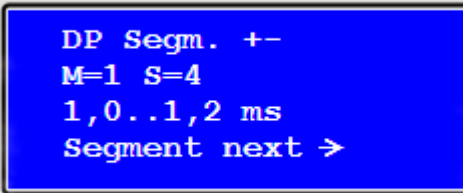
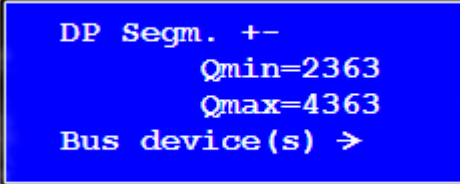

Fig. 20: Live Status with segment status 1

To the right of "DP Segm." in line 1, the display shows changes in the live list (added and dropped bus stations). The following displays are possible:

1. The number of bus stations has not changed during the test:
  - No display of live list changes
2. One or more bus stations have been added during the test:
  - "+" display
3. One or more bus stations have been dropped during the test:
  - "-" display
4. One or more bus stations have been added and one or more dropped during the test:
  - "+ -" display

The live list should usually not change when a PROFIBUS system is stable. In line 2, you see the number of masters (M) and slaves (S). Line 3 indicates the token rotation time.



```
DP Segm. +-  
      Qmin=2363  
      Qmax=4363  
Bus device(s) →
```

Fig. 21: Live Status with segment status 2

Besides changes in the live list, segment status 2 also displays the worst quality index of all bus stations in line 2 and the best quality index in line 3 (signal quality, see PROFIBUS Diagnostics Suite manual).

#### 8.3.1.2 Station status

This function displays the station status for each bus station, i.e. for all masters and all slaves.

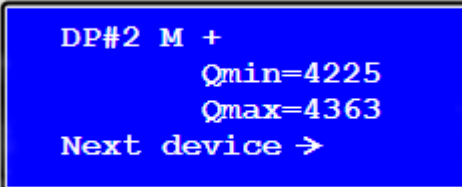

```
DP#2 M +  
      Qmin=4225  
      Qmax=4363  
Next device →
```

Fig. 22: Live Status with station status of a master

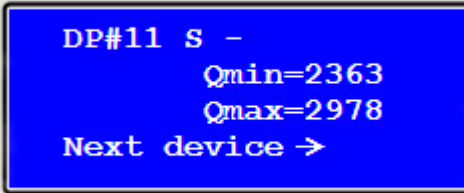

Fig. 23: Live Status with station status of a slave

The PROFIBUS address of the bus station is displayed right after “DP#” on the left of line 1. On the right, you see the live list changes (see page [29](#)) for this bus station. Line 2 shows the worst quality index and line 3 the best quality index tested for this bus station (signal quality, see PROFIBUS Diagnostics Suite manual).

Note: The update rate for the live status substantially depends on the number of bus stations and the signal quality.

### 8.3.2 Quick Test function

This function is currently in preparation and will soon be available via firmware update.

### 8.3.3 Trend function

This function is currently in preparation and will soon be available via firmware update.

### 8.3.4 Master Simulator function

The master simulator is disabled by default when you switch on the tool. You can only select a baud rate on the display and thus start the master simulator if no other master is active.

### 8.3.5 Settings and Help functions

The following options are available:

- Settings/Delete all internal memory locations: Deletes all quick tests and trend recordings
- Settings/Current language: Toggles between English and German
- HW Information: Displays on two screens the firmware and FPGA versions and the date and time of the last factory calibration.
- Help: Briefly describes the functionality of the four function keys.

## 9 Firmware Update

Firmware updates are made available as required. They are provided with the updates to the PC software (see page [16](#)) and allow access to new or improved functionality. How to update the firmware is described in detail in the separate “PROFIBUS Diagnostics Suite – Getting Started” manual.

## 10 Maintenance and Servicing

The PROFIBUS Tester 4 is maintenance-free and does not require calibration. Repairs may only be carried out by the device manufacturer. All returns must be made in the supplied carrying case. Please also include a brief fault description and a phone number at which we can contact you should we need further details. In case of returns within the warranty period, please also enclose a copy of the invoice or delivery note.

## 11 Troubleshooting

Problem	Causes and remedies
<p>The display of the PROFIBUS Tester 4 remains blank.</p>	<p>Possible cause:</p> <ul style="list-style-type: none"> <li>• The PROFIBUS Tester 4 always needs an additional external power supply.</li> </ul> <p>Remedy:</p> <ul style="list-style-type: none"> <li>• Use the supplied external AC adapter to connect the tool to the mains power supply.</li> <li>• When connected directly to a 24 VDC power supply: check the voltage at the terminals</li> </ul> <p>Alternative cause:</p> <ul style="list-style-type: none"> <li>• The tool is defective.</li> </ul> <p>Remedy:</p> <ul style="list-style-type: none"> <li>• Return the tool for servicing (see page <a href="#">32</a>)</li> </ul>
<p>The display shows the following error message: "USB ERROR - Refer to manual or disconn. for stand-alone mode".</p>	<p>Possible cause:</p> <ul style="list-style-type: none"> <li>• This error message can be caused by poor physical connection via USB ("loose" contact).</li> </ul> <p>Remedy:</p> <ul style="list-style-type: none"> <li>• Check the USB cable and connector.</li> </ul>
<p>The PROFIBUS Tester 4 is not detected by the "PROFIBUS Diagnostics Suite" PC software (Start Page or Tool Explorer).</p>	<p>Possible cause:</p> <ul style="list-style-type: none"> <li>• The tool was connected to the PC before installing the software. The Windows hardware wizard was terminated with an error message. As a result, the PROFIBUS Tester 4 is displayed as defective in the Device Manager, under Softing Fieldbus Interface, which you can access by selecting Control Panel -&gt; System -&gt; Device Manager.</li> </ul> <p>Remedy:</p> <ul style="list-style-type: none"> <li>• Open the Windows Control Panel, select System, change to the Hardware tab and start the Device Manager. Under the Softing Fieldbus Interface entry, right-click the PROFIBUS Tester 4, which will be marked as defective, and click "Update Driver" (Windows Update – No, not this time; Install the software automatically).</li> </ul> <p>Alternative cause:</p> <ul style="list-style-type: none"> <li>• USB problem</li> </ul> <p>Remedy:</p> <ul style="list-style-type: none"> <li>• Replace the USB cable, use the USB port directly on the PC or notebook (no hubs, etc.).</li> </ul>
<p>The baud rate is not detected automatically on a live PROFIBUS.</p>	<p>Possible cause:</p> <ul style="list-style-type: none"> <li>• Massive disturbances in the bus physics.</li> </ul> <p>Remedy:</p> <ul style="list-style-type: none"> <li>• Manually set the baud rate in the PC software and repeat the test.</li> </ul>

If you need to contact Softing's support team, you will find the contact data on the back cover of the manual.

## 12 Specifications

Power supply	Via external AC adapter 100 V .. 240 VAC 50/60 Hz (galvanically isolated) or direct connection to 24 VDC $\pm 20\%$ , approx. 0.5 A (without galvanic isolation)
RS485 (DP)	<p>PROFIBUS D-sub connector (female), 9-pin, power supply for ext. bus termination</p> <p>Protocol and frame analysis: PROFIBUS DP and DPV1, automatic baud rate detection 9.6 kbit/s .. 12 Mbit/s</p> <p>Signal analysis: PROFIBUS DP, DPV1, FMS and MPI; signal quality index 0 .. 5000 determined from signal waveform as well as signal/noise ratio and rise time; signal sampling with 8/16 samples per bit</p> <p>Oscillogram display: Test range <math>\pm 5V</math>, resolution 40 mV, sampling rate 192 MSamples/s, for signal details: 2,400 sampled points, for oscillogram analysis: 8,192 sampled points</p> <p>Topology scan: Active, maximum distance 230 m, accuracy <math>\pm 2</math> m</p>
USB	V 2.0, high speed 480 Mbit/s, galvanically isolated
Trigger (in preparation)	IN : L=0 .. 0.8 V; H=2.4 .. 24 V; pulse > 10 $\mu$ s, active high OUT: approx. 5 V, active low (connection to storage oscilloscope)
Dimensions	HxWxD: 35 x 170 x 110 mm
Weight	Test tool without cable: approx. 0.45 kg, complete with carrying case, without accessories: approx. 3.9 kg
Protection class	IP 20
Permissible ambient conditions	Operating temperature 0 .. 50 °C Storage temperature -20 .. 70 °C, Air humidity 10 .. 90% without condensation
Conformity	CE, FCC, VCCI
Operation	Via PC/notebook or alternatively in stand-alone mode via four-line display and four function keys
Test results	Display and detail analysis using the PROFIBUS Diagnostics Suite PC software application

## 13 General Notes

### 13.1 Lithium Battery

Warning! This product contains a lithium backup battery. The lithium content is not more than 1 g. The battery has been successfully tested by the manufacturer in accordance with the UN Manual of Test and Criteria (test procedures of Part III, Sub-Section 38.3). Improper handling of lithium batteries can cause the batteries to ignite or explode and pose a burn hazard to users. If the product is properly handled, this battery does not need to be replaced during the lifetime of the product. Therefore, opening the product is unnecessary and not permitted. The product must only be operated within the specified temperature range. Do not expose to heat above this temperature range and keep away from open fire. Store in a dry place.

### 13.2 CE Conformity

This product complies with the requirements of the EC Directives 2004/108/EC Electromagnetic Compatibility (EMC directive)

Emission: EN 61000-6-4 Generic Emission Standard (industrial environments)  
EN 55011 Group 1 Class A (ISM Product Standard)  
EN 55022 Class A (ITE Product Standard)

Immunity: EN 61000-6-2 Generic Immunity Standard (industrial environments)  
EN 61326-1 (Measurement, Control and Laboratory Equipment Product Standard)

A Declaration of Conformity in compliance with the above standards has been made and can be inspected at Softing AG on request.



NOTE:

For compliance with the legal EMC requirements, the other components (PROFIBUS devices, AC adapter, etc.) must also meet these requirements. To meet the EMC conditions, the product must be installed and connected in accordance with the installation instructions.

Warning! This is a Class A product. In a domestic environment this product may cause radio interference in which case the user may be required to take adequate measures.

**Softing AG**

Industrial Automation  
Richard-Reitzner-Allee 6  
85540 Haar  
Germany

**www.softing.com**

Tel. +49 89 45656-326 (Support)  
Tel. +49 89 45656-340 (Sales)  
Fax +49 89 45656-488  
Email: [support.automation@softing.com](mailto:support.automation@softing.com)